



# Schwiebacher Abbruch Technik

Werkstatt • Lager • Service seit 1977

## D-82229 Seefeld (bei München)

Graf-Toerring-Seefeld-Strasse 9b / 17

Tel. 08152 / 998 969-0 Fax.- 9

### T.55/T.60 GRABENRÄUM-SCHWENK-LÖFFEL *optimal\** (2 Zylinder stehend, flaches Profil und rückwertiger Schneide) für Bagger von 12,5 bis 19 to

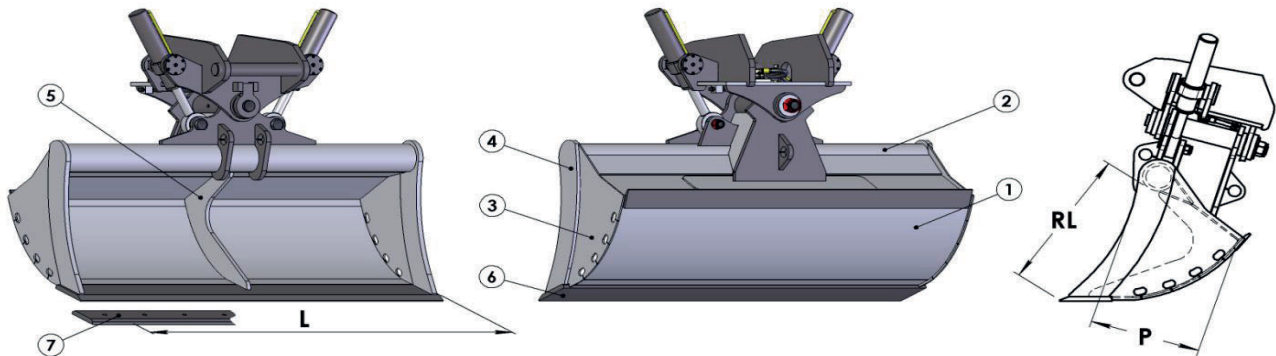
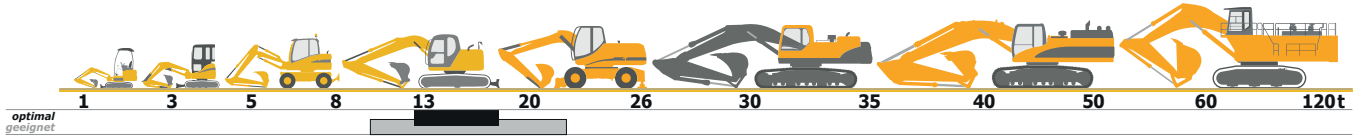

Klasse Class Classe	Bestell Nr. Code Code	L mm.	Cap. SAE Lt.	Anz. Zylinder Cylinders Vérins	Gewicht kg Weight Poids	RL mm.	P mm.	Preis Price List Tarif	Unterschraubmesser Bolt on Blade Lame boulonnées
<b>T.55</b> <b>T.60</b> <b>12,5-19</b> <b>ton</b>	T55ORZ150	1500	363	2	641	569	427	/	7 Optional
	T55ORZ180	1800	442	2	688				
	T55ORZ200	2000	495	2	719				
	T55ORZ220	2200	548	2	759				
		<b>1</b>	<b>2</b>	<b>3</b>	<b>4</b>	<b>5</b>	<b>6</b>	<b>/</b>	<b>7 Optional</b>
<b>Material</b>	<b>Material Matériel</b>	Fe 510	Fe 510	Fe 510	Fe 510	Fe 510	Hb 400	/	Hb 400
<b>Materialstärke</b>	<b>Thickness Espessure</b>	8 mm	127 x 14.2 mm	6 mm	20 mm	15 mm	200 x 25 mm	/	200 x 20 mm

\*optimal = für Bagger von 12,5 bis 19 t mit Standard-Ausrüstung.

**T.55** Akermann H 5; Atlas 1302/1304M/1304LC/1404M/14 04LC; Benati 90/120/140/145/3.15/3.16/3.17; Benfra 4R/4C/5/9.05/9.06; Case 588/9013/CX 130/CS 135SR/WX 125/WX 145; Caterpillar EB 120/205/206/M 312/M 313C/M 315/311C/312C/314C; Cosmoter BAT 12/14; Daewoo Doosan DH 130.2/S 110/S 130W-III/S 1 30LCV/S 140WV/S 160W V/S 140LCV/S 150LCV; Fai 1000 C/CH/GTH; Fiat Hitachi FH 120/FH 125W/FH 130.3/EX 135; Fiat Kobelco E 13 5/E 135SR/E 145W; Fiat-Allis E 12/FE 14/FE 16; Ford 42; Furukawa W 625E/W 630/W 635/W 725LS/W 730LS; Halla HE130W/H E 130LC; Hitachi ZX 130/ZX 135US/ZX 130W; Hydromac H 75; Hyundai 120W/R 130W-3/140W-7/R 130LC-3/R 140LC-7; JCB JS 130/JS 130W/JS 140/JS 145W; Kobelco SK 120/SK 135SRLC/90 3B; Komatsu PC 130/PW 130-7/PC 138US-2/PC 150.3; Lalesi 50/221/222; Liebherr R 310B/R 312/A 312 LIT/A 314/A 316/A 900; Mecalac 714MC/714MW; MF 330; New Holland E 145/E 135SRLC/SRL/MH CITY/MH 4.6; O&K RH 4/RH 4PLUS/RH 4PMS/RH CITY/MH 4/MH CITY/MHS/MH PLUS/RH 4.5/RH PLUS; PMI 700/8.15/8.17; Poclain TCS 45/60; ROCK 75; Samsung SE 130LC.2/SE 130W.3; Takeuch TB 1140; Volvo EC 130/EW 130/EC 140B/EW 140B/EC 150/EW 160 B.

**T.60** Akermann H 7B/H 7C; Atlas 1604M/1604LC/1622; Benati 160/3.18; Benfra 6C/7R/7.07/7.08/9.07/9.08/9.20; Case 688/688B/788/CX 160/WX 150/WX 165/WX 170/CX 180; Caterpillar 211/212/213B/214/214B/315/317/318/M 316C/M 318C/315C; Cosmoter BAT 16; Daewoo Doosan DH 170/DH 180/S 170III/V/S 175LCV/S 180WV; FAI 1100; Fiat Hitachi FH 150.3/EX 165/FH 150 W.2/FH 150W.3; Fiat Kobelco E 165 LC/E 175W; Fiat-Allis FE 18; Ford 44/45; Furukawa 635E; Hitachi ZX 160LC/ZX 180LC/ZX 160W/ZX180W; Hydromac H 85; Hyundai R 160LC-3/7/R 170W-3/R 180LC-3/7; JCB JS 150/JS 160LC/JS 160W/JS 175W/JS 180LC; Kobelco SK 150/SK 160LC/904/905B/SK 170LC; Komatsu PC 160-7/PW 160-7/PW 170/PC 180-7/PW 1 80-7; Lalesi 80/341/341HD; Liebherr A 9 00C/A 900B LIT/A 902 LIT/A 314 LIT/A 316 LIT/R 317; MF 350D/350E; New Holland E 175/MH PL US/MH PLUS C/MH 5.6; O&K RH 5/RH 5PLUS/RH 5 PMS/MH 5/MH 5PMS/RH 5.5; PMI 900/8.18; Poclain 61/75/688; ROCK 100; Samsung SE 170W.3; Volvo EC 160B/EC 170/EW 170/EC 180B/EW 180B.

geeignet = für Bagger von 10 bis 22 t je nach Ausrüstung. Andere Klassen/Größen bedingt geeignet. Bei Bedarf bitte anfragen!