



Schwiebacher Abbruch Technik

Werkstatt • Lager • Service seit 1977

D-82229 Seefeld (bei München)

Graf-Toerring-Seefeld-Strasse 9b / 17

Tel. 08152 / 998 969-0 Fax.- 9

T.68/T.69/T.70 GRABENRÄUM-SCHWENK-LÖFFEL *optimal** (2 Zylinder stehend, rundes Profil) für Bagger von 26 bis 43 to

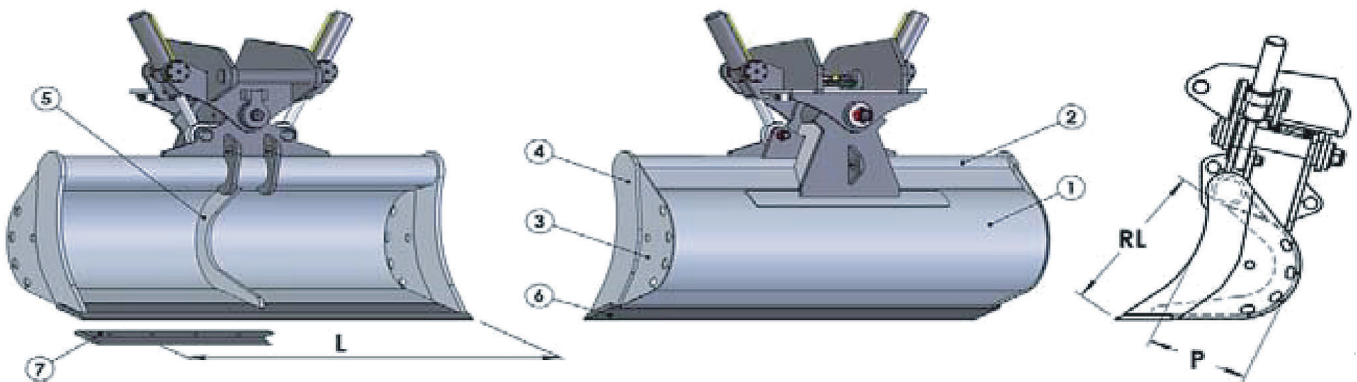
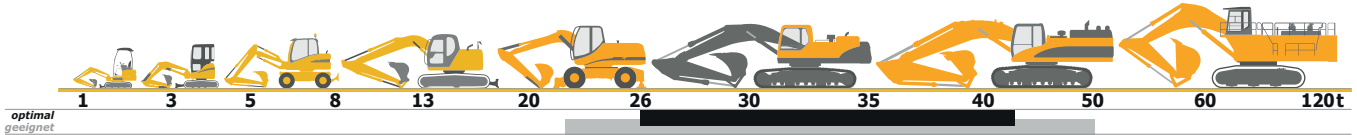

Klasse Class Classe	Bestell Nr. Code Code	L mm.	Cap. SAE Lt.	Anz. Zylinder Cylinders Vérins	Gewicht kg Weight Poids	RL mm.	P mm.	Preis Price List Tarif	Unterschraubmesser Bolt on Blade Lame boulonnées
T.68 T.69 T.70 26-43 ton	T68ORR180	1800	956	2	1210	860	529	/	/
	T68ORR200	2000	1074	2	1263				
	T68ORR220	2200	1191	2	1337				
	T68ORR240	2400	1309	2	1390				
	T68ORR250	2500	1366	2	1416				
		1	2	3	4	5	6	/	7 Optional
Material	<i>Material</i> Matériel	Fe 510	Fe 510	Fe 510	Fe 510	Fe 510	Hb 400	/	Hb 400
Stärke	<i>Thickness</i> Espessure	10 mm	177.8 x 20 mm	10 mm	30 mm	25 mm	300 x 30 mm	/	250 x 25 mm

*optimal = für Bagger von 26 bis 43 t mit Standard-Ausrüstung.

T.68 Akermann H 14B; Atlas 1804/1804M/180 4LC/1902; Benati 230CSB/270CSB/370/3.28/3.30; Benfra 12C/9.11/9.12; Case 1288CK/CX 290; Caterpillar 225D/229D/231/322B/322C/323/325B/C/D; Cosmoter BAT 25C; Daewoo Doosan DH 280/280 LCIII/V/290LCV/S 300LCV; Fiat Hitachi FH 270.3/ EX 285; Fiat Kobelco EX 285LC; Fiat-Allis FE 28; Ford 50; Furukawa 645LS; Hitachi ZX 28 0LC/ZX 280LCN; Hydromac H 150/H 180; Hyundai 280LC/290 LC-3/7; JCB JS 3 00/JS 330; Kobelco SK 300/909; Komatsu PC 270/PC 280/PC 290-7/PC 300; Laltesi 541; Liebherr A 932 LIT/A 934 LIT/R 924B LIT/R 924 LIT; MF 550; New Holland E 305EL/LC; O&K RH 9E/F/G/PMS/RH 9.5/RH 8.5; PMI 1300/1500/8.30/8.34/9.26/9.30/9.35; Poclair 125; ROCK 150; Samsung SE 280 LC.2; Volvo EC 280/EC 290B.

T.70 Akermann H 16C; Atlas 2004; Benati 335/450/310CSB; Benfra 9.32; Case 1488, 9033/CX 330/CX 350; Caterpillar 330B/C/D/E; Daewoo Doosan DH 320/S 330III/V/S 360LCIII/S 340LCV; Fiat Hitachi FH 300.2/FH 330.3/EX 355; Fiat Kobelco EX 355EL/LC/BEN; Furukawa 650E; Halla HE 360LCH; Hitachi ZX 350LC/ZX 350LCN; Hydromac H 200; Hyundai H 230/H 270/R 320LC-3/7/R 360LC-3/7; Kobelco SK 330LC/912; Komatsu PC 340-7/PC 360; Laltesi 350 HD/551HD; Liebherr A 944 HD LIT/R 934B LIT/R 942 LIT/R 944 LIT/R 944B LIT; New Holland E 335LC/NLC/E 3 85EL/LC/BEH; O&K RH 12.5/RH 14; PMI 14855; Poclair 170; ROCK 200; Samsung SE 350LC.2; Volvo EC 330B/EC 340/EC 360B.

geeignet = für Bagger von 22 bis 45 t je nach Ausrüstung. Andere Klassen/Größen bedingt geeignet. Bei Bedarf bitte anfragen!